

E-Z Burr Tool Specifications – Micro Series

E-Z Micro Series Tools

For holes .040" to .092" (1.00mm to 2.33mm).

Tool #	Hole Range	Hole Range	A	B	C
	Inches	mm			
CAR0400	.0400 - .0415	1.00 - 1.06	1.90	.15	.25
CAR0420	.0420 - .0445	1.07 - 1.13	1.90	.15	.25
CAR0450	.0450 - .0480	1.14 - 1.22	1.90	.15	.25
CAR0485	.0485 - .0515	1.23 - 1.31	1.97	.16	.31
CAR0520	.0520 - .0535	1.32 - 1.36	1.97	.16	.31
CAR0540	.0540 - .0565	1.37 - 1.44	1.97	.16	.31
CAR0570	.0570 - .0610	1.45 - 1.55	2.06	.19	.38
CAR0615	.0615 - .0650	1.56 - 1.65	2.10	.19	.41
CAR0655	.0655 - .0685	1.66 - 1.74	2.13	.19	.44
CAR0690	.0690 - .0715	1.75 - 1.82	2.21	.21	.50
CAR0720	.0720 - .0745	1.83 - 1.89	2.21	.21	.50
CAR0750	.0750 - .0775	1.90 - 1.97	2.21	.21	.50
CAR0780	.0780 - .0800	1.98 - 2.03	2.24	.24	.50
CAR0805	.0805 - .0835	2.04 - 2.12	2.24	.24	.50
CAR0840	.0840 - .0875	2.13 - 2.22	2.24	.24	.50
CAR0880	.0880 - .0920	2.23 - 2.34	2.24	.24	.50

All cartridges must be used with a Cartridge Holder (part# CAR-HOLDER) featured below.

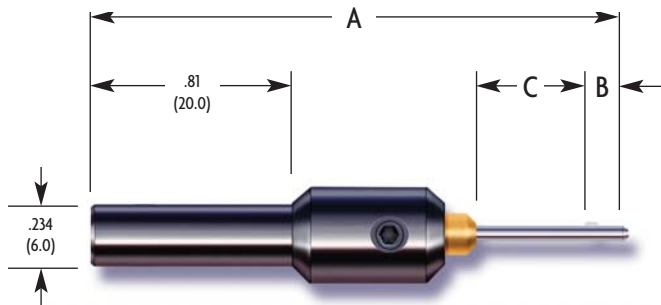

Cartridge Holder



Cartridge (includes blade & arbor)



Set Screw

